



DTF6000 TRAILFINDER DIGITAL OPTICAL POSITION SCANNER



- **Determines relative bar position via internal fiber optic block and multiplexed scanned germanium diode array .**
- **LED Array Display of product pass line for correct alignment.**
- **Automatic Gain operating via edge control margin evaluation.**
- **Analog output for product position.**
- **Digital outputs for product presence.**
- **Robust IP66 aluminum housing with water coolant chamber and separate air purge facility.**

Typical Applications

Metals Industry: Loop Control, Position of hot bar, rod or wire. Centering of Hot Strip. Edge detection & positioning.

Other Industries: Edge detection and positioning of hot product.

Description

The Trailfinder operates via internal microprocessor and a multiplexed scanned InGaAs Photodiode arrays. It provides both analog output and displays the products hot edge position via bar display.

While normal Optical Position Scanners purely detect the product above a pre-set threshold as the Trailfinder operates via a programmable control margin it ensures precise and repetitive positioned output regardless of the product's size or temperature. Hence, it is not adversely affected by lens contamination, hot scale, metalwork or steam in the field of view. As a consequence it provides very stable performance in difficult and variable environments such as found in Mill Stands that can defeat other Scanners.

Being a digital device, the Trailfinders' response time may be precisely set to accommodate black spots, etc. without detriment to its accuracy. Furthermore, the Trailfinder detects the product edge precisely and repeatability regardless of the product size and changes in temperature. Various analog outputs are available according to requirement.

The Trailfinder operates via internal InGaAs Photodiode arrays segmented into 40 segments and scanned in 2 ms for an exceptionally fast output . The IR signal input is transmitted via an internal fiber optic block that ensures precise scanning is maintained without loss of signal yet blocking out the unwanted radiating heat from the device. This unique use of fiber optic technology facilitates compact construction with high performance.

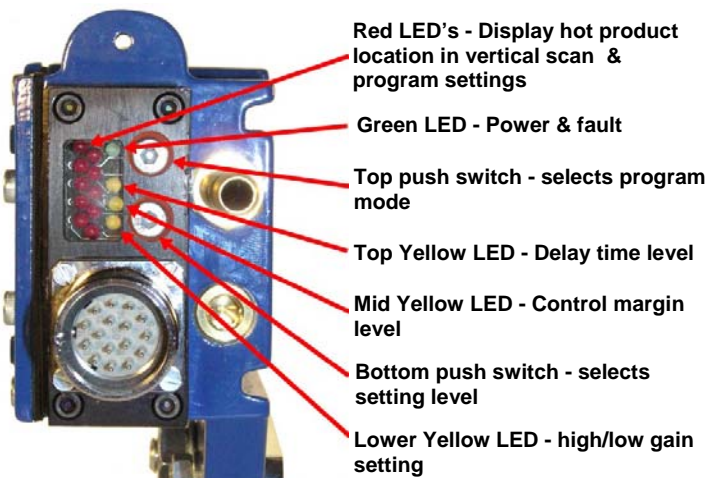

MODULOC Technology - The Total Sensor Solution

MODULOC Control Systems Ltd.

Wheathamstead, Hertfordshire, AL4 8SB United Kingdom
Phone: +44 (0)845 8736501 FAX: +44 (0)1582 831980
E-Mail: sales@moduloc-intl.com Website: www.moduloc-intl.com

MODULOC Control Systems, Inc

500 Garden City Drive. - Suite 2B, Monroeville, PA 15146 USA
Phone: 412-824-1260 FAX: 412-824-8890
E-Mail: sales@moduloc-usa.com Website: www.moduloc-usa.com

Housing Specifications

Housing: Aluminum AL6, Oven baked blue paint
Housing Rating: IEC IP66, DIN, 89011
Weight w/o Cable: 2.5 Kg
Cable Length: 1.5 M
Cooling: Standard: -D Water Cooled & Air Purged

Air & Optional Water Specifications

Air Pressure: 1 - 2 cu ft./min at 5 PSI for normal conditions, no instrument dry air and 10 - 15 PSI for severe conditions
Water Pressure: 1 - 2 Bar
Water Volume: Regulate between 0.5 - 1 liter/min.
Water Temp.: For Ambient Temperature up to +80°C (176°F) use industrial quality water at 25°C (77°F)
 For Ambient Temperature up to +120°C (250°F) use water Chilled to 5°C (41°F).

Performance

Model	DTF 6015	DTF 6022
Horizontal Field of View	30 degrees	45 degrees
Horizontal Resolution	40 Bits	40 Bits
Vertical field of view	3 degrees	4 degrees
Reproducibility	Resolution	Resolution

Technical Info

Product Presence Outputs (3 total)	Cradle Relay, SPNO, 250 VAC, 8A NPN & PNP Outputs 400 mA, 45 V, 2A peak Opto-isolated Output 300 V, 150 mA	Supply Voltage	110 VAC ± 15% 50/60 Hz or 24VDC ±10%
		Power Consumption	2 Watts
Analog Output	0 -10 VDC Standard (Optional: +/- 10VDC, +/- 15VDC or 4-20mA)	Operating Temperature	-20°C (-4°F) to +50°C (122°F) without air or water cooling -20°C (-4°F) to +60°C (140°F) with air cooling -20°C (-4°F) to +90°C (194°F) inline vortex air cooling +2°C (36°F) to +120°C (250°F) with water cooling
Linear resolution	±0.2% of full scale	Humidity	Max 90% RH (non condensing)
Response time	10 milliseconds	Storage Temperature	-20°C - +50°C
Product Temperature Limit	Minimum 450°C (842°F) Maximum 1200°C (2192°F)	Self Check	Continuous automatic self check & remote self check facility
Sensing Elements	Electronically In GaAs Photodiode Array (IR filter removes visible spectrum)	Array Scan Time	2 mS

* Optional Logic Alarm Now Available

Control Margin Illustration

Typical hot background signal

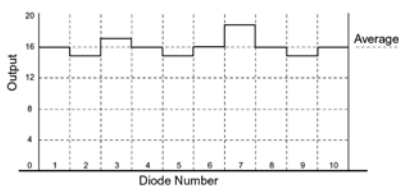
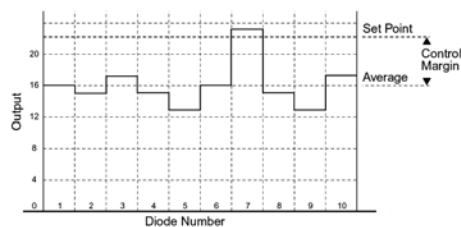

Chart illustrating signal from typical hot background

Typical signal with passing hot bar



This chart illustrates the control margin. Where the background IR is uniform then the control margin can be set to a lower figure. Any hot product passing needs to give a signal that exceeds the set point.

Dimensions

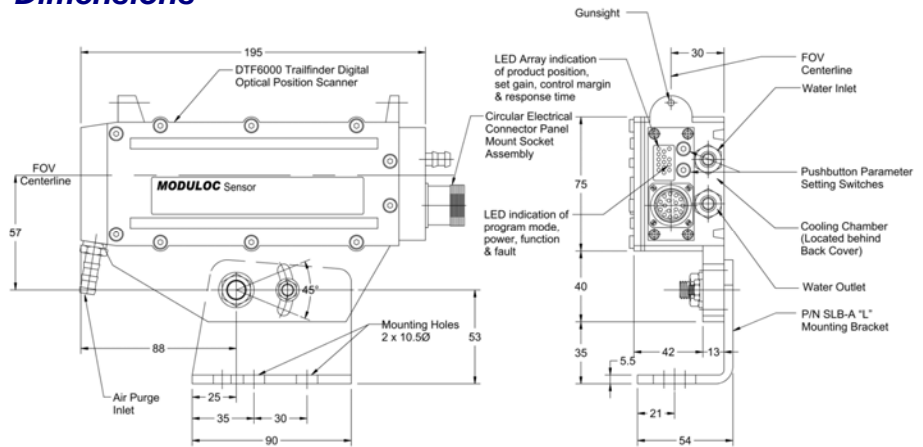

MODULOC Technology - The Total Sensor Solution

MODULOC
Control Systems

We reserve the right to alter specifications without prior notice. Specifications without tolerances are typical values.

Your Local Sales Representative:



Bulletin MC-DTF6000-09-01
January 2009