



LT2020-SC LASER DISTANCE METER



- **Visible Class II Laser providing precise distance measurement**
- **Operates off Natural Surfaces up to 30 Meters (98 feet), off a white target at 100 Meters (328 Feet) and off a special reflector target at 150 Meters (492 Feet)**
- **Measuring rate as low as 20msec off of a white surface or a special reflector target**
- **Provides +/- 2mm to +/- 5mm accuracy**
- **Low in cost yet long range**
- **RS232 & RS422 Serial Interface**
- **Programmable 4-20 mA Analog Output**
- **Programmable Digital Output & Offset**

Typical Applications

Product Material	Length, width, level and position of product.
Material Handling	Automated Storage/Retrieval Systems and positioning of mobile equipment.
Metals Industry	Measure/Position slab, billet, bloom or bar.
Crane Control	Positioning of cranes & crane trolleys.
Collision Avoidance	Distance alarm between vehicles using reflective target.

General Description

The LT2020-SC Laser Distance Meter operates over a substantial range off static or passing product in difficult areas in harsh environments. The LT2020-SC measures distances off of natural surfaces over a working range up to 30 meters or off of white surfaces over a range of up to 100 meters. For operation with automated positioning control of material handling transport systems a white reflective target is used. The LT2020-SC can provide a measuring rate as low as 20 milliseconds when used with a white target or a special reflector target.

Especially suited for precise detection and measurement of cold/hot product at temperatures up to 600°C. For higher product temperature our Model LT2000-HT is available for measurement of cold/hot product at product temperatures up to 1200°C.

Straightforward alignment is easily accomplished via the visible red laser measuring beam.

Accuracy is +/- 3mm to +/- 5mm according to ambient temperature. Repeatability is +/- 0.5mm and the user scalable resolution is 0.1mm.

The zero offset and the span of the 4 - 20 mA analog output are both user programmable. The distance offset is also user programmable, this allows the user to define a zero point independent of the analog output zero offset.

The LT2020-SC is provided with a user programmable digital switching output which is triggered by exceeding in the positive or negative direction a user programmable distance threshold. The hysteresis of the digital switching output is also programmable.

The LT2020-SC is a robust Laser Distance Meter. Standard operating temperature 50°C.

The low cost LT2020-SC laser distance meter provides a highly accurate measurement reading. It is ideal for length and width determination, and checking position of product in and around furnace areas.

The LT2020-SC is supplied a standard with either RS232 or RS422/RS485 serial interface with a 2400 to 38,400 Baud Rate & a programmable 4 - 20 mA 16 BIT analog output. An optional ProfiBus DP Gateway Interface Box is available. ProfiBus DP, DeviceNet and Ethernet Interface Options will soon be available.

MODULOC Technology - The Total Laser Solution

MODULOC Control Systems Ltd.

Wheatthamstead, Hertfordshire, AL4 8SB United Kingdom
Phone: +44 (0)845 8736501 FAX: +44 (0)1582 831980
E-Mail: sales@moduloc-intl.com Website: www.moduloc-intl.com

MODULOC Control Systems, Inc.

500 Garden City Drive. - Suite 2B, Monroeville, PA 15146 USA
Phone: 412-824-1260 FAX: 412-824-8890
E-Mail: sales@moduloc-usa.com Website: www.moduloc-usa.com

Housing Specifications

Housing: Aluminum AL6, Oven baked blue paint
Housing Rating: IEC IP65, DIN 89011
Weight w/o Cable: 2.4 Kg (5.3Lbs)
Cable Length: 2 M (Optional 5, 10 & 15M Available)

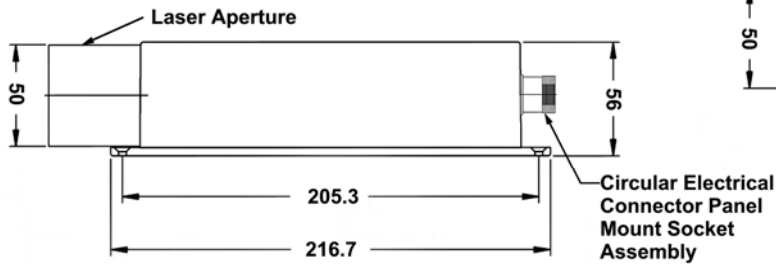

LT2020-SC Dimensions

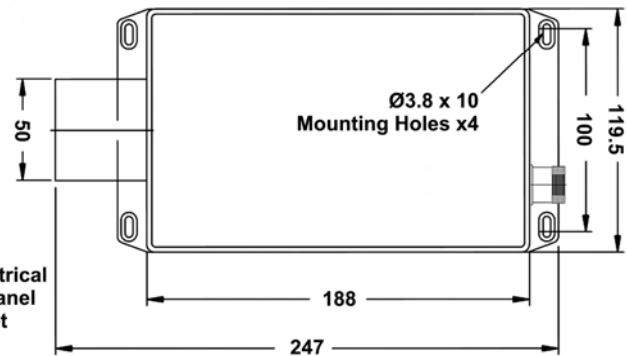

General Specifications

Operating range ¹⁾ (Type of surface)	Natural Surface: 0.2M (7.8IN) to 30M (98FT) White Surface: 0.2M (7.8IN) to >100M (328FT) Special Reflector: 2M (6.6FT) to > 150M (492FT)	Supply Voltage	10 - 30 VDC
Accuracy (according to temperature range)	± 3 mm (0.118in) for 15°C (59°F) to 30°C (86°F)	Operating Temperature	-10°C (14°F) to +50°C (122°F)
	± 5 mm (0.197in) over full operating temperature range	Power Indication:	Red LED
Resolution	0.1 mm user (programmable & scalable)	Storage Temperature	-20°C (-4°F) to +70°C (158°F)
Repeatability	±0.5 mm (0.0197in)	Product Temperature Limit	Standard 600°C (Hi-Temp model available)
Scale (programmable)	Output can be M, cm, mm, yard, feet, inch	Serial Interface	RS232 or RS422/RS485 (2400 - 38,400 baud)
Measuring Time ²⁾ (According to type of surface reflectivity)	Any Surface: 160 msec. to 6 sec. (typically 200 msec) ³⁾	Communication Protocol	Half Duplex via ASCII codes.
	White Surface: 100 msec (in DW Measuring Mode)	Programming	via Hyper-terminal & Supplied Software
	White Surface: 20 msec (in DX Measuring Mode)	Optional Interface*	ProfiBus gateway connection box
Laser Wavelength	659nm, Visible Red	Auto Distance Tracking	Can be programmed to start at power on
Laser Classification	Safety Class 2 (DIN EN 60825-1), Class II	Digital Output	High value output with adjustable threshold, logic & hysteresis. 0.5 A limit
Laser Power	1 mW	Analog Output	Programmable 4-20mA, 16 BIT (0.15%) with 500 ohm Load Resistance. Programmable Zero & Span. Temperature drift of < 50ppm/°C.
Laser Divergence	0.6 mrad		
Laser Spot Diameter	6mm(0.236in) at 10M (32.8ft), 60mm (2.36in) at 100M (328ft)		
MTTF	32,000 hrs		
Trigger Input	Adjustable with delay & hi/lo adjustment (DF Measuring Mode)		

1). Ranges shown are for DT, DW & DM measuring mode. DS measuring mode has a range of 0.5M (197.7IN) to 7M (23FT)

2). Measuring Time can also be preset in intervals of 240 msec to 6 seconds in DT measuring mode and preset in intervals of 150M to 3.75 seconds in DS measuring mode.

3). In DT & DS measuring mode

***Coming Soon: New Interface Options - ProfiBus DP Interface, DeviceNet Interface, and Ethernet Interface.**

*Optional BR22 Laser Interface

The BR22 Laser Interface provides a localized LCD display of distance measurement and programming of the laser operational parameters via keypad operation and a user-friendly menu. The BR22 operates from 90 - 240 VAC supply and provides the required DC power to the laser.

The BR22 communicates to the laser via an RS422 Serial Interface to accommodate long cable runs. When powered on the BR22 automatically starts and programs the laser to configured operational parameters. The BR22 provides a 4-20 mA analog output of the laser distance measurement as well as RS232 & RS422 serial interfaces. The BR22 has a relay output with adjustable threshold for product presence. Parameters for the BR22's analog output, host serial interface and relay output as well as for the laser are configured using the keypad and are displayed via a menu on the BR22 LCD display.

The BR22 is housed in an IP65 rated painted aluminum enclosure and can be placed directly on the mill floor. The operating temperature range is -10° C to +50°C.

The BR22 is available in several configurations, for operation of 1 or 2 lasers, for product length, thickness or width measurement, and for positioning control. The BR22 is also available with a supply voltage of 24VDC ±20%.

MODULOC Technology - The Total Laser Solution

MODULOC
Control Systems

Your Local Sales Representative:



We reserve the right to alter specifications without prior notice. Specifications without tolerances are typical values.

Bulletin MC-LT2020-SC-09-01
January 2009