



## LT3001 LASER DISTANCE METER



- **Advanced totally safe Class I Laser for precise distance measurement.**
- **Measuring range of 0.5 m to 300 m off natural surfaces and more than 3000 m off a high gain reflector.**
- **Provides +/- 20 mm accuracy with 1 mm resolution.**
- **RS232 Serial Interface and optional RS422 Serial Interface**
- **Programmable 4-20 mA Analog Output**
- **Two Programmable Digital Outputs**
- **External Trigger Input**
- **Extruded aluminum housing rated IP67.**
- **Secondary Environmental Enclosures are available for additional protection for indoor, outdoor and elevated temperature applications.**

### Typical Applications

<b>Product Material</b>	Length, width, level and position of product.
<b>Material Handling</b>	Automated Storage/Retrieval Systems and positioning of mobile equipment.
<b>Metals Industry</b>	Measure/Position slab, billet, bloom or bar.
<b>Crane Control</b>	Positioning of cranes & crane trolleys.
<b>Collision Avoidance</b>	Distance alarm between vehicles using reflective target.

### General Description

The LT3001 Laser Distance Meter operates via a pulsed time-of-flight (TOF) measurement technique. The LT3001 Laser Distance Meter operates over a substantial range off of a static or moving target. It measures up to 300 meters off of natural surfaces and up to 3000 meters off of a special high gain reflective surface. The LT3001 transmits ultra-short light pulses at the rate of 2000 measurements per second, measures the TOF to the reflector and back to derive the distance and transmits this data information via an interface to a computer, PLC or an analog instrument. The LT3001 can also be used to measure speed in the range of 0 m/s to 100 m/s (at 0.5 m to 700 m distance).

The standard LT3001 is supplied with a RS232 serial interface with a 1200 to 480,600 Baud Rate, a programmable 4 - 20 mA 16 BIT analog output, 2 programmable digital outputs and trigger input. Optional interfaces are available for RS422, ProfiBus DP and SSI.

The standard LT3001 comes complete with integral heating, an LED status display and a red Laser pointer. The LED display is located on the back panel and is used to monitor of the current working status during normal operation. The red Laser point of the Pilot Laser is used to aid in alignment.

Measuring Accuracy is +/- 20 mm at 2 kHz measuring rate and at 100 Hz output rate and +/- 60 mm at 2 kHz measuring and output rate. Resolution is 1mm. Measure range depends on reflectivity and surface of the target.

The zero offset and the span of the 4 - 20 mA analog output are both user programmable. The distance offset is also user programmable, this allows the user to define a zero point independent of the analog output zero offset.

The LT3001 is provided in a dust and waterproof protected IP67 enclosure. Standard operating temperature range is -40°C to 60°C. Optional Secondary Environmental Enclosures are available for additional protection for indoor, outdoor and elevated temperature applications. An optional alignment telescope is available to aid in alignment of long distances.

## MODULOC<sup>®</sup> Technology - The Total Laser Solution

### MODULOC<sup>®</sup> Control Systems Ltd.

Wheatthamstead, Hertfordshire, AL4 8SB United Kingdom  
Phone: +44 (0)845 8736501 FAX: +44 (0)1582 831980  
E-Mail: sales@moduloc-intl.com Website: www.moduloc-intl.com

### MODULOC<sup>®</sup> Control Systems, Inc.

500 Garden City Drive. - Suite 2B, Monroeville, PA 15146 USA  
Phone: 412-824-1260 FAX: 412-824-8890  
E-Mail: sales@moduloc-usa.com Website: www.moduloc-usa.com

## LT3001 Dimensions

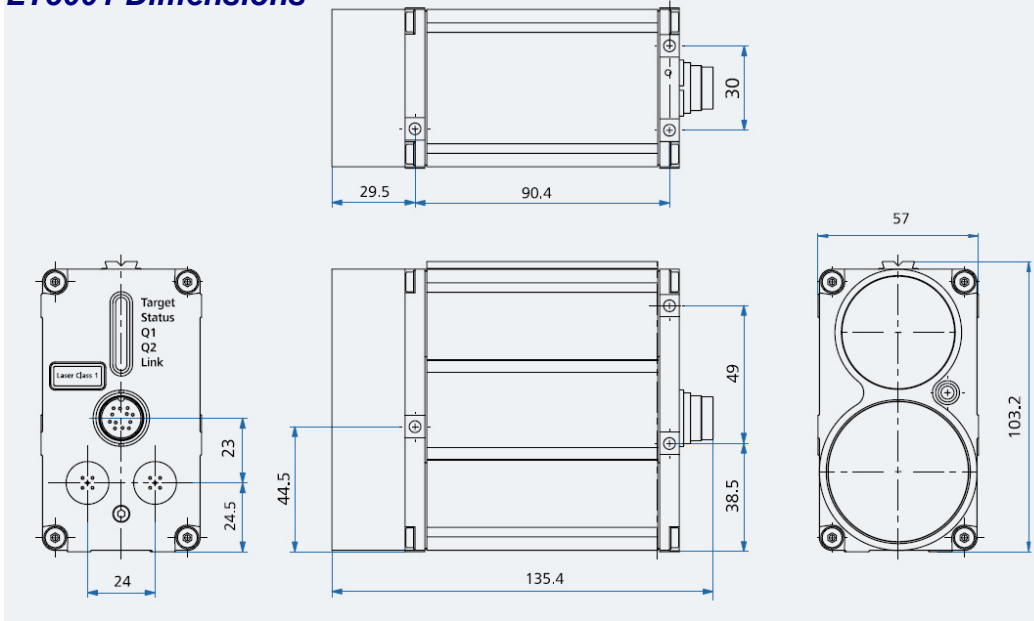

## Housing Specifications

**Housing:** Aluminum, Oven baked blue paint  
**Housing Rating:** IEC IP67, DIN 89011  
**Weight w/o Cable:** 0.8 Kg (3.75lb)  
**Connector:** IP67 Plug/Socket  
**Cable Length:** 2.0 M (Optional 5M and 10M Available)

## General Specifications

Measuring principle	Laser-pulse-time-of-flight measurement	Supply Voltage	10 - 30 VDC
Measuring range <sup>1)</sup>	Natural Surface: 0.5M (19.68IN) to 300M (980 FT) <sup>2)</sup> Special Reflector: 0.5M (19.68IN) to 3000M (9800 FT)	Power Consumption	< 5 W (operation without heating) 11.5 W (operation with heating at 24 V)
Accuracy (according to surface reflectivity)	± 20 mm (0.787in) 2 kHz measuring rate & 100 Hz output rate ± 60 mm (2.36in) 2 kHz measuring rate & output rate	Operating Temperature	-40°C (-40°F) to +50°C (122°F)
Resolution	1 mm	Storage Temperature	-40°C (-40°F) to +70°C (158°F)
Measuring Time	Standard version: 0.5 ms, Optional version: 0.1 ms	Relative Humidity	15% to 90%
Operating modes	Single measurement, continuous measurement, mean value, external triggering (selectable near-field suppression and window functions)	Shock resistance	10 g / 6 ms persistence shock DIN ISO 9022-3-31-01-1
Velocity Measuring range	0 m/s ... 100 m/s <sup>3)</sup>	Standard Serial Interface	<b>-R2</b> RS232 (9600 - 460,800 baud)
Velocity Measuring time	0.1 sec to 0.5 sec <sup>3)</sup>	Optional Serial Interface	<b>-R4</b> RS422 (9600 - 460,800 baud)
Laser Wavelength	905 nm (infrared)	Communication Protocol	Half Duplex via ASCII codes, 8N1
Laser Classification	Laser Class 1, DIN EN 60825-1:2003-10, Class I	Programming	via Hyper-terminal & Supplied Software
Laser Power	1 mW	Auto Distance Tracking	Can be programmed to start at power on
Laser Divergence	1.7 mrad	Optional ProfiBus Interface	<b>-P</b> DP-V0 slave   IEC 61158 / IEC 61784 9.6 kBaud to 12 MBaud, automatic detection, external terminator, slave address selectable via Profibus
Laser Spot Diameter	6mm(0.236in) at 10M (32.8ft), 60mm (2.36in) at 100M (328ft)	Optional SSI Interface	<b>-S</b> 50 kHz to 1MHz, 25 µs pause 24bit, binary or gray-encoded, adjustable
Laser Pointer	Wavelength: 625nm, Visible Red	(2) Digital Outputs	high-side-switch, max. load 0.22 A, short-circuit-proof, adjustable windowing
Laser Pointer	Classification: Safety Class 2 (DIN EN 60825-1), Class II	Analog Output	Programmable 4-20mA
Laser Pointer Modes	on, off, blinking	Trigger Input	trigger In/Out, edge and delay selectable, trigger level 3 - 30VDC,

1) depending on target reflectivity, stray light influences and atmospheric conditions

2) natural, diffusely reflecting surfaces, do not use bad reflective materials (dark / black surfaces) as target under 10 m

3) distance range to target: 0.5 m to 700 m

## MODULOC<sup>®</sup> Technology - The Total Laser Solution

**MODULOC<sup>®</sup>**  
Control Systems

Your Local Sales Representative:



We reserve the right to alter specifications without prior notice. Specifications without tolerances are typical values.

Bulletin MC-LT3001-10-01  
January 2010