



MODEL MD9207 HIGH SPEED HOT PRODUCT DETECTOR



- **Background Suppressed Eliminates False Trips.**
- **Interchangeable remote lenses: 1°, 2°, 4°, 7° F.O.V. spot & ½° x 25° F.O.V. precision slit rectangular.**
- **High Temp lens ratings of 180°C, 400°C & 1000°C.**
- **Response Time of 0.5 msec.**
- **Digital Pulsed & Locked Switching Outputs.**
- **Two Output Timers with 0-100 msec Adjustment.**
- **Remote Self-check facility.**
- **Robust lens mounts available including air purged, air cooled or water cooled.**

General Description

The MD9207 Remote High Speed Hot Product Detector is an electronic optical sensor built to meet the higher speed detection requirements within the modern steel mill. Armored fiber optic leads allow the lens to be installed close to the process line in high ambient, while allowing the controller to be mounted in an accessible area. The MD9207 provides a 0.5 msec "pulsed" N.O. PNP transistor output and a "latched" N.O. PNP transistor output, initiated by the passing of a hot leading edge. In addition two independent latched reed relay outputs are also provided. The detector's response time is virtually independent of the target temperature. In addition, background radiation is filtered out by processing the IR signal present in the field of view of the lens through both a slow and fast amplifier channel. A traditional threshold adjustment is not required.

A wide variety of remote lenses are available. Impervious to water or steam and built to withstand the harshest environments. Used in conjunction with flexible armored optic lead, these lenses provide a high level of optical accuracy by allowing the selection of the ideal lens arrangement for the installation. Robust lenses with temperature ratings of 180°C, 400°C can be mounted close to the hot product. All remote lenses incorporate filters to minimize sensitivity to extraneous light. For general tracking, spot lenses are commonly used. Where high accuracy is required or the product deviates about the center line (i.e. Rod Mill) a ½° x 25° precision slit rectangular lens should be utilized. This slit rectangular lens is also highly suited to Strip Mills. Various robust lens mounts are available including air purged, air purged & air cooled, and air purged & water cooled.

The MD9207 is provided with a remote self check feature that is remotely initiated. When activated the detector will switch and its performance checked.

Operation

To meet the requirements for higher speed detection within steel mills, the MD9207 was developed with two high speed transistor outputs, dual reed outputs and supplementary analog output.

The MD9207 is supplied with two types of outputs:

1. A 0.5 msec PNP pulse output initiated by the passing of the hot leading edge.
2. Two latched outputs, one PNP transistor and one reed relay. Both are initiated by the presence of hot product but remain latched while the hot product is in view.

The detector's response time to an approaching hot edge is virtually independent of the target temperature. Background radiation is filtered out by processing the IR signal present through both a slow and fast channel. Fluorescent lighting affects both channels similarly and is therefore cancelled out. Faster changes in detected IR are only seen in the fast channel and hence triggers the output.

The detectors performance is determined by how much the target differs in the temperature to the background as well as the sharpness of rise (minimum required temperature change is 100°C). It is calibrated to IR values generally found in the mills. Greater temperature changes make little difference thus a traditional sensitivity control is not needed.

Background suppression adjustment is provided in that the detector may be adjusted to respond to sharper changes in IR level. This effectively allows higher levels of background IR to influence performance.

MODULOC Technology - The Total Sensor Solution

MODULOC Control Systems Ltd.

Wheatthamstead, Hertfordshire, AL4 8SB United Kingdom
Phone: +44 (0)845 873 6501 FAX: +44 (0)158 283 1980
E-Mail: sales@moduloc-intl.com Website: www.moduloc-intl.com

MODULOC Control Systems, Inc.

500 Garden City Drive. - Suite 2B, Monroeville, PA 15146 USA
Phone: 412-824-1260 FAX: 412-824-8890
E-Mail: sales@moduloc-usa.com Website: www.moduloc-usa.com

General Information

Remote Electronic Controller

Housing: Aluminum AL6, Oven baked black enamel
Housing Rating: IEC IP66, DIN, 89011
Weight w/o Cable: 1.7 Kg
Connector: IP65 Plug/Socket
Cable Length: 1.5 M

Remote Lenses:

Precision Rectangular Slit: FOV: 1/2° x 5°, 1/2° x 15° & 1/2° x 25°; rated 160°C.
Stainless Rectangular Slit: FOV: 2° x 25°; rated 400°C
Stainless Tubular Spot: FOV: 1°, 2°, 4° or 7°; rated 180°C or 400°C.

Optic Cables:

Armored Stainless Sheath available in lengths from 2 meters to 15 meters in 1 meter lengths; rated 180°C or 400°C.

Dimensions

Model MD9207 Remote Electronic Controller

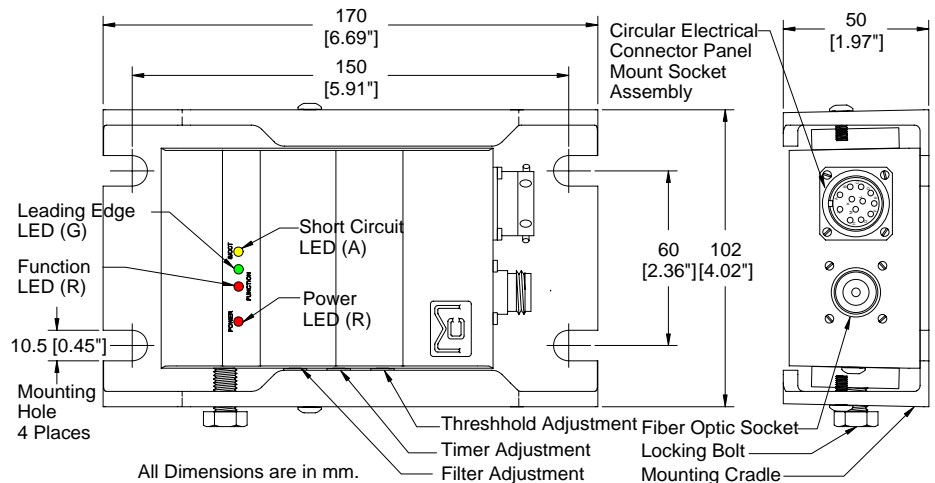

All Dimensions are in mm.

General Specifications

For dimensional information & specifications on remote lenses, lens mounts and optic cables please see Bulletin MC-MD9000L

Sensing Element	Germanium Diode	Supply Voltage	24 VDC ± 15%
Power Indication:	Red LED	Power Consumption	5 Watts
Function Indication	Red LED	Operating Temperature	-20°C to +60°C (-4°F to 140°F)
Short Circuit Indication	Amber LED	Storage Temperature	-25°C to +75°C (-13°F to 167°F)
Leading Edge Indication	Green LED	Latching Timers	Independent Timer for both Pulse and Latch Outputs. Adjustment range 0-100 msec. Pulse timer resets with each trailing/leading edge. Latch timer clears when product passes.
Detection Technique	Differential comparison between background and hot product.		
Pulse Output Adjustment (Leading Edge)	Potentiometer, 20-turn, with external adjustment	Pulse Output (Leading Edge)	Normally Open PNP Transistor, 24VDC/500mA. Switching speed 0.5 msec, to leading edge.
Latch Output Adjustment (Product Presence)	Potentiometer, 20-turn, with external adjustment	Latch Output #1 (Product Presence)	Normally Open PNP Transistor, 24VDC/500mA protected. Switching speed 2 msec, on and off.
Remote Self-Check	Single wire to 24 DVC internal line	Latch Output #2 (Product Presence)	Reed Relay Output, SPNO, 24VDC, 0.5A Switching speed 2 msec, on and off.

Smallest Detectable Product when utilizing a 1/2° x 25° Lens

Percentage of Vertical F.O.V. Required with Hot Product	
Steel Temp.	Nominal 350°C Preset Trip
400°C	10%
450°C	5%
500°C	1%
600°C	1/2%
800°C	Less than 1/2%

Construction

The MD9207 control unit contains all the electronics and switching circuitry in an aluminum watertight enclosure with a mounting cradle for easy installation. Highly visible LED indicators are located on the front of the control unit for power, function and short circuit indication. Input power and outputs are available through a quick connect plug. The MD9207 remote spot lenses are mounted in a stainless steel tube housing with various circular field of views. Various mounting brackets with cooling facilities are available. The remote wide angle lenses are housed in an aluminum cast housing with integral air purge/water cooling facilities. All remote lenses have a 180°C temperature rating (400°C optional for spot lenses).

Consult factory for additional information or application assistance.

MODULOC Technology - The Total Sensor Solution

MODULOC
Control Systems

We reserve the right to alter specifications without prior notice. Specifications without tolerances are typical values.

Your Local Sales Representative:



Bulletin MC-MD9207-09-01
January 2009