



MDCLS SERIES - DIGITAL CAMERA LEVEL SENSORS



MDCLS400R300-RB & MDCLS700R400-RB

- **CCD Camera** determines level via digital signal processing.
- **Non-contact measurement** of Launder and Head box level
- **Auto-gain circuit** brightens laser beam when steam in FOV
- **Operates directly off molten metal at up to 1000/1832°C**
- **Compact unit** for inserting in confined space away from heat
- **Single purged aperture** viewing penetrates heavy steam.
- **Purge nozzle baffles** block IR reflections and contamination
- **Stand-off clearances** of 400 and 700 mms
- **Measurement frequency** of 1000 Hz and 0.5 mm resolution
- **Serial, Analog and Digital Outputs**
- **Digital alarm** for Out-of-range and over temperature

Model Performance

Model	MDCLS400R300-RB	MDCLS700R400-RB
Level Measured range (mm/In)	300	400
Clearance Stand-off (mm/In)	400	700
Resolution (mm)	0.5 mm	0.5 mm
Reproducibility (mm/In)	±0.5 mm	±0.5mm
Linearity (mm/In)	±0.5 mm	±0.5 mm
Laser Spot size (mm/In)	Ø3 mm	Ø 3 mm

Typical Industrial Applications

Aluminium Casting Industry - Die Cast Aluminium Moulders - Lead and Brass Copper Foundries

In all these Industries long term reliable precise level control is essential on the Launder, Troughs and Head boxes in use throughout the typical casting plant. With this in mind these Level Sensors incorporate digital outputs confirming level measurement is being transmitted and the other internal temperature is within limits.

General Description

The MDCLS Digital Camera Level Sensors are compact units with integrated optics and signal processor for precise measurement of the liquid level. A focused laser spot is illuminated on the liquid surface and the image distance determined by internal CCD Camera.

LED's clearly indicate when the object is at center or at limit of measuring range. Installation software is provided for connection to a PC and to display measured values. Measurement of data is via both RS232 and 4-20 mA analog output. Operate at a measuring frequency of 1000 measurements per second a serial output update frequency of 1000 measurement points per sec. or lower

The MDCLS 700R300 & 700R400 Sensor Units are housed in a robust Secondary stainless steel enclosure provided with Vortex Cooled air inlet venting as Air purge out of the protective nozzle. This enables replacement of the Camera without disturbing mounting configuration. The connection cable is also encased in a stainless flexible conduit to protect it from hot metal splash.

MODULOC Technology - Lasers for Precise Product Measurement

Configurable Filters

All Models have a programming/select functionality. Group mode is the main feature. In Group Mode a running average is calculated over a user specified number of measuring points. The user also programs the sensor to disregard a number of, usually all, bad (zero) measuring points before calculating the average value. The average values are calculated at full measuring frequency and are used for converting the analog signals.

Several other filters are available to ensure robust measurement values are provided.

Dimensions

MDCLS400R300-RB & MDCLS700R400-RB

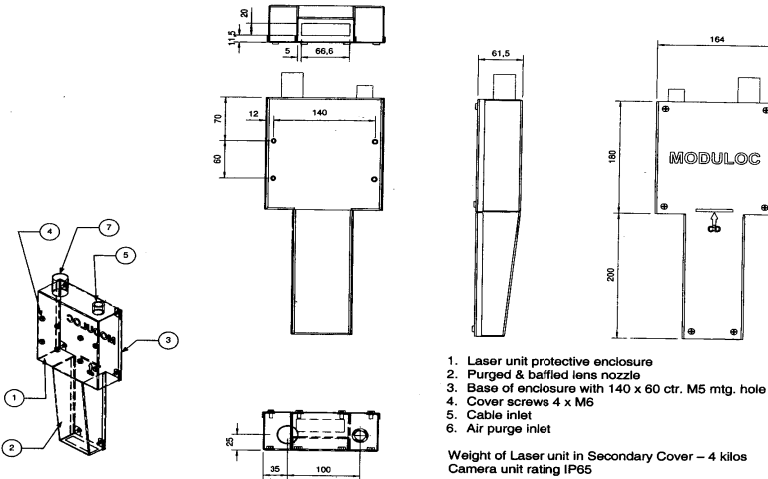

General Specifications

Serial Output	RS232 Baud Rate 38400	Supply Voltage	24VDC \pm 10%
Serial Output	RS422/485 (optional)	Power Consumption	4.5 Watt
Digital Output	1/10 mm	Digital Outputs (Two)	Temp okay and device measuring
Analog Output	4-20mA	Operating Temperature	0°C to +45°C (32°F to 113°F)
Measuring Frequency	1000 Hz	Storage Temperature	-20°C to +70°C (-4°F to 158°F)
Temperature Deviation	\pm 0.03% of F.S./°C	Product Temp. Limit	Standard 1000°C
Light Source	Visible 665 nm Laser	Laser Class	Class II, IEC 2

MODULOC Technology - Lasers for Precise Product Measurement

MODULOC
Control Systems

We reserve the right to alter specifications without prior notice. Specifications without tolerances are typical values.

Your Local Sales Representative:



Bulletin. MC-MDCLS-11-09
November 2009