

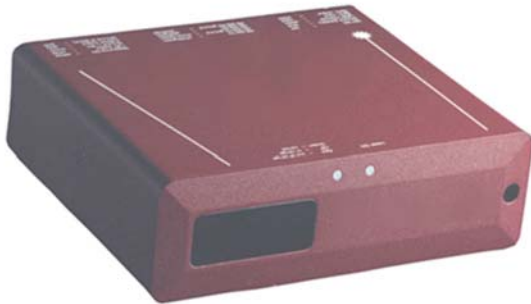

MLS505 LASER TRIANGULATION METERS



- **Laser Triangulation & CCD array technique with digital signal processing.**
- **Non-Contact Measurement of Distance, Displacement, Thickness & Difference.**
- **Works on almost any surface.**
- **2 High temperature versions available for target surface temperatures of 1200°C or 1500°C**
- **Measured range: 450 - 550 mm. (17.7 - 21.7 in.)**
- **Resolution: 0.01 mm**
- **Measurement frequency of 1000 Hz, 2000Hz or 5000Hz**
- **Robust Design**
- **Serial & Analog Outputs**
- **Synchronized thickness measurement with two sensors.**
- **Secondary Environmental Enclosure are available including Air Purged, Air Cooled and Water Cooled with Air Purging.**

Performance

Measured range	450 - 550 mm	Measuring range	100 mm
Center distance	500 mm	Light Source	Visible 655/670 nm Laser
Resolution	0.01 mm	Laser Spot Size	Ø 1 mm
Reproducibility (+/-)	±0.01mm	-S2 Option (2KHz measuring update)	Available
Linearity (of Full Scale)	±0.5mm	-S5 Option (5KHz measuring update)	Available
Temperature Deviation	±0.03% of F.S./°C	-HM & -MM Options (high temp.)	Available

Typical Applications

- **Liquid Level Control**
- **Distance Measurement**
- **Thickness Measurement**
- **Weight/Volume Control**
- **Constant Tension Control**
- **Roll Diameter**
- **Profile Measurement**
- **Control of Vacuum in Containers**
- **Control of Surface Treatments**
- **Molten Metal Level**
- **Vibration Monitoring of a Rotating Object**
- **Measurements for Quality Control and Statistics**
- **Measurements for feedback in Production Lines**

General Description

The MLS505 Laser Triangulation Meter (LTM) is a compact unit with integrated optics and signal processor for precise measurement of distance or product thickness and width. A focused laser spot is illuminated on the object and the image distance determined by internal CCD array. LED's indicate when the object is at the center or is outside of the measuring range. Installation software is provided for connection to a PC and to display measured values. Measurement of data is via RS232 and analog outputs.

The MLS505 operates at a measuring and serial output update frequencies of 1,000 measurements per second. The MLS505 has programming/select functionality. The main feature is Group Mode. In Group Mode a running average is calculated over a user specified number of measuring points. The user also programs the meter to disregard a number of, usually all (if there are any zero measurement results), before calculating the average value. The average values are calculated at full measuring frequency and are used for converting the analog signals.

Two identical MLS505 LTM's when connected together automatically provide change in thickness, width or difference values. The standard MLS1950 operates at a 1kHz measuring & update frequency and has a serial interface baud rate of 38400. The optional -S2 model operates at a 2kHz measuring frequency and at a 1kHz or 2kHz update frequency, and has a serial interface baud rate of 38400 or 115200. The optional -S5 model operates at a 5kHz measuring frequency, and at a 1kHz, 2½kHz or 5 kHz update frequency and has a serial interface baud rate of 38400, 115200 or 230400. The baud rate of 230400 requires option -R4 RS422/RS485 serial Interface.

The MLS505 laser triangulation meters has a broad range of usage for measurement off surfaces where other devices fail. Ideal for measuring off wood, plastic, glass, rubber, paper, foam, textiles, food product, cold, hot or molten metals as well as various liquids.

MODULOC[®] Technology - Lasers for Precise Product Measurement

MODULOC[®] Control Systems Ltd.

Wheathamstead, Hertfordshire, AL4 8SB United Kingdom
 Phone: +44 (0)1727 821313 FAX: +44 (0)1727 826804
 E-Mail: sales@moduloc-intl.com Website: www.moduloc-intl.com

MODULOC[®] Control Systems, Inc.

2808 Broadway Blvd. - Suite 201B, Monroeville, PA 15146 USA
 Phone: 412-824-1260 FAX: 412-824-8890
 E-Mail: sales@moduloc-usa.com Website: www.moduloc-usa.com

Dimensions

Housing: Steel/Aluminum/Glass
Housing Rating: IEC IP64
Weight w/o Cable: 4.0 Kg (8.8lbs)
Cable Length: 2.5 M

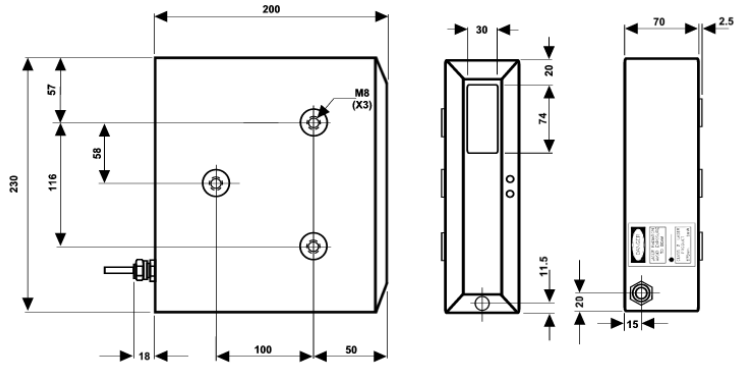

General Specifications

Serial Output	RS232 Standard - up to 38400 baud	Supply Voltage	24VDC \pm 10%
Serial Output	RS422/485 (optional)	Power Consumption	4.5 Watt Max.
Digital Output	Digital output 1/10 values of full range	Humidity	Max 90% RH (non condensing)
Analog Output	1-9VDC/4-20mA ¹⁾	Operating Temperature	0°C to +45°C (32°F to 113°F)
Measuring Frequency	1000 Hz (Optional 2000 Hz & 5000 Hz available)	Storage Temperature	-20°C to +70°C (-4°F to 158°F)
Update Frequency	1000 Hz	Product Temp. Limit	Standard 450°C (842°F) See -MM & -HM
Light Source	Visible 655/670 nm Laser	Laser Class	Class II, IEC2 ²⁾

1) =Analog Output is pre-set at the factory and can be configured, at an additional cost, to suit specific requirements. Analog output frequency is the same as the measuring frequency.
 2) =Laser class IIIR (3R) is supplied with combination of options -HM & -S2. Laser class IIIB (3B) is supplied with combination of options -HM & -S5, and all -MM versions.

Option: -S2 Increased measuring performance compared to standard model operates at 2kHz measuring frequency, and at 1 kHz or 2 kHz update frequency and has a serial interface baud rate of 38400 or 115200.

Option: -S5 Increased measuring performance compared to standard model. Operates at 5kHz measuring frequency, and at 1 kHz, 2½kHz or 5 kHz update frequency and has a serial interface baud rate of 38400, 115200 or 230400. The baud rate of 230400 requires option -R4 RS422/RS485 serial interface.

Option: -R4 Provides a RS422/RS485 serial interface in place of the standard RS232 serial interface.

Option: -HM High Temperature 1200°C (2192°F)

The -HM options are designed for target surfaces temperatures up to 1200°C. Sensors with this option are specifically designed for measurement on objects that are more than 450°C (842°F) hot, like hot rolled steel or molten metals and glass. These laser class II sensors achieve target temperature up to 1200°C (2192°F), for surfaces with mirror type properties a special sensor with laser class IIIB can be supplied.

All the models in the MLS family can be delivered with the -HM option. The -HM option can be supplied with either 1kHz, 2kHz or 5kHz versions. The laser class changes to a IIIR when the -HM option is supplied with the 2kHz option. The laser class changes to a IIIB when the -HM option is supplied with the 5kHz option.

It is important to stress, that the -HM option only concerns the target temperature. Maximum Ambient temperature is the standard 45°C.

The -HM Option can also be required when there is a high risk of harmful false light as is the case with bright sunlight, both direct and reflected.

Optional water cooled secondary environmental enclosures with air purging are available.

Option: -MM High Temperature 1500°C (2732°F)

The -MM option is designed for target surface temperatures up to 1500°C (2732°F).

Sensors that are supplied with this option are specifically designed for measurement of molten metals that are greater than 1200°C (2192°F). These laser sensors achieve target temperatures up to 1500°C (2732°F) and can be used on surfaces with mirror type properties.

All the models in the MLS family can be delivered with the -MM option. The -MM option can be supplied with either 1kHz or 2kHz versions. The laser class changes to IIIB when the -MM option is supplied.

Optional Water Cooled Secondary Environmental Enclosures with Air Purging are available.

Thickness Measurement

All MLS LTM's when connected to an identical³⁾ MLS model will automatically transform into the Master or the Slave of a synchronized Thickness Measurement System .

The Master LTM reads the digital distance data sent from the Slave LTM over the RS232 serial interface, and after taking its own distance information into account, will output the calculated change in thickness to the serial interface as well as to the analog output.

Thus two MLS LTM's will measure thickness, width or difference without an additional control box or special calibration from the factory. This is a unique characteristic of the MLS Laser Triangulation Meters.

³⁾ = MLS500, MLS700 & MLS1100 have the unique capability of connecting to any other MLS model to form a Master - Slave Thickness Measuring System.

MODULOC[®] Technology - Lasers for Precise Product Measurement

MODULOC[®]
Control Systems

Your Local Sales Representative:

We reserve the right to alter specifications without prior notice. Specifications without tolerances are typical values.



Bulletin. MC-MLS-505-08-01
January 2008