



## Type MD9000 - PST-01 (1°) Air Purged Tubular Lens Holder



- ***Stainless steel design for long life in harsh environments.***
- ***Provides precise alignment of the lens to the target with air purge capabilities.***
- ***The air purge inlet is a standard tubing connection.***

### ***General Description***

This purged mounting bracket is entirely constructed of stainless steel for long life in harsh environments. This mount offers precise alignment of the lens to the target with air purge capabilities. The air purge inlet is a standard tubing connection.

This purged mount is particularly useful in environments where steam and particulates must be cleared from the field of view with an air purge.

## ***MODULOC Technology - The Total Laser Solution***

### ***MODULOC Control Systems Ltd.***

Wheathamstead, Hertfordshire, AL4 8SB United Kingdom  
Phone: +44 (0)845 8736501 FAX: +44 (0)1582 831980  
E-Mail: sales@moduloc-intl.com Website: www.moduloc-intl.com

### ***MODULOC Control Systems, Inc.***

500 Garden City Drive. - Suite 2B, Monroeville, PA 15146 USA  
Phone: 412-824-1260 FAX: 412-824-8890  
E-Mail: sales@moduloc-usa.com Website: www.moduloc-usa.com

## PST-01 Dimensional Info

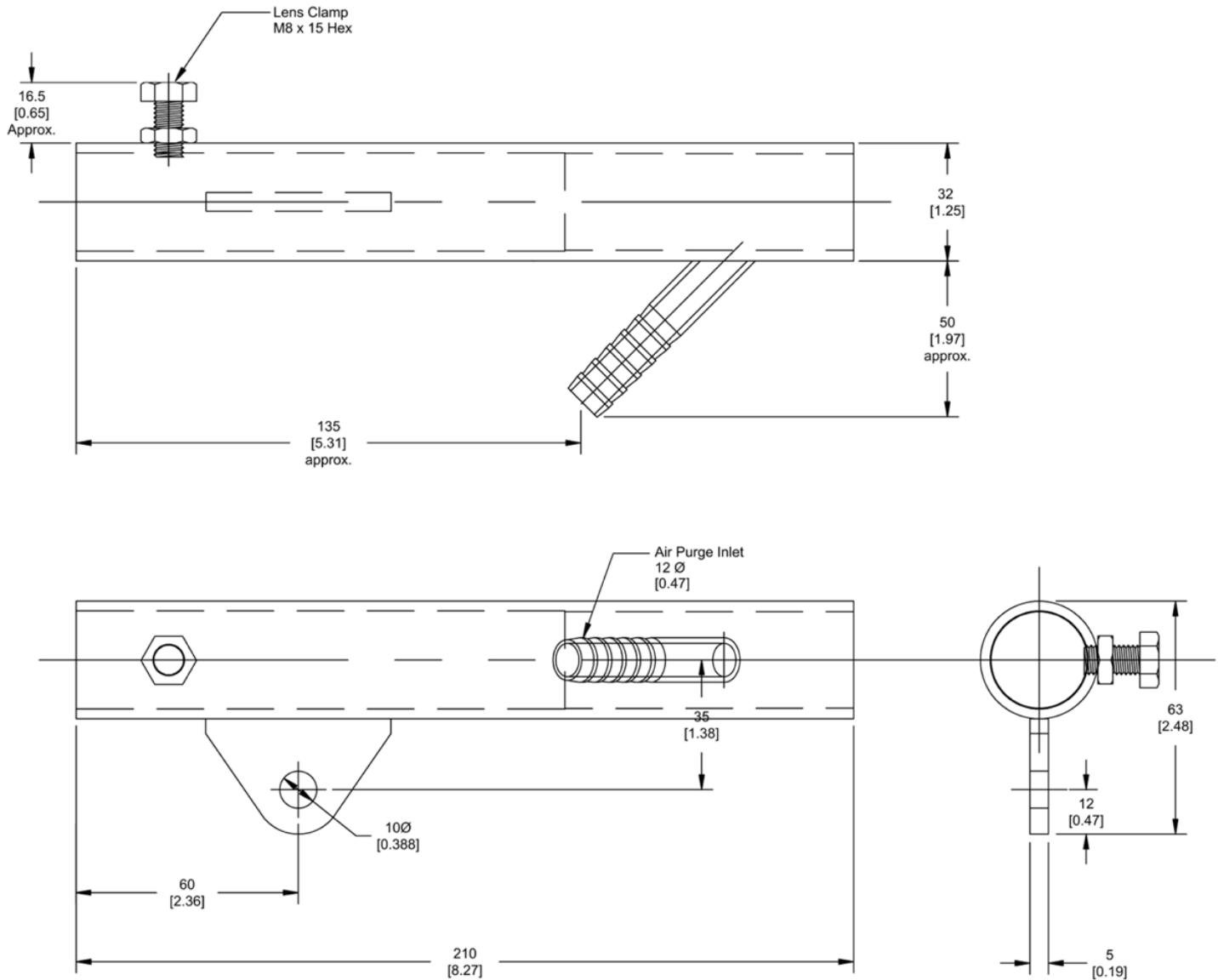

## MODULOC Technology - The Total Laser Solution

**MODULOC**  
Control Systems

Your Local Sales Representative:

We reserve the right to alter specifications without prior notice. Specifications without tolerances are typical values.



Bulletin MC-PST-01-09-01  
January 2009